



Table of Contents



- [1. Squirrel Cage Induction Motor](#)
 - [Construction](#)
 - [Working](#)
 - [Advantages](#)
 - [Disadvantages](#)
 - [Applications:](#)
- [2. Wound Rotor or Slip Ring Induction Motor](#)
 - [Construction](#)
 - [Working](#)
 - [Advantages](#)
 - [Disadvantages](#)
 - [Applications](#)
- [Difference Between Squirrel Cage Induction Motor and Slip Ring Induction Motor](#)
- [FAQs](#)
 - [Why are the rotor bars of a squirrel cage motor skewed?](#)
 - [Which motor is better for heavy-duty applications?](#)
 - [Why is it called a squirrel cage?](#)
 - [Which motor has higher starting torque?](#)

Three-phase induction motors are one of the most trusted machines in the electrical world. Whether it's a factory, workshop, or a water pump system, these motors keep everything running smoothly. To understand them better, we must know the types of three phase induction motor used in industries today.

So, based on rotor construction and design, three phase induction motor are primarily classified into **two types**:

1. **Squirrel Cage Induction Motor**
2. **Wound Rotor or Slip Ring Induction Motor**



1. Squirrel Cage Induction Motor

The squirrel cage induction motor is the most common and widely used among all 3 phase induction motor types. If you have ever seen a motor running a fan, blower, or pump in a factory, it was most likely a squirrel cage motor.

Construction

The squirrel cage induction motor has a three-phase stator winding placed in slots to produce the rotating magnetic field. Its rotor is made of aluminium or copper bars placed in slots and short-circuited at both ends by end rings, forming a cage-like structure.

The rotor bars are slightly skewed to reduce [cogging](#) and ensure smooth starting. The motor also includes a laminated core to reduce losses and a strong outer frame.

Because of its simple and strong construction, the motor becomes extremely rugged, almost maintenance-free and cost-effective.

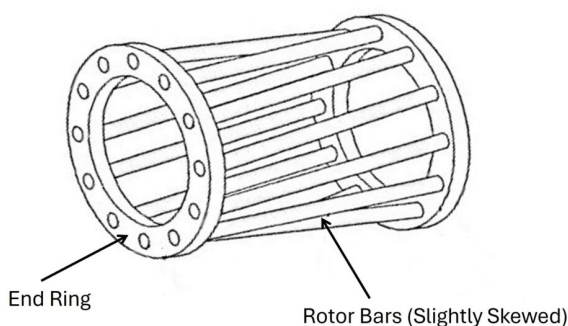

Working

When AC supply is given to the stator, it creates a rotating magnetic field



that induces current in the rotor. And, as we know, a current-carrying conductor placed in a magnetic field experiences a force—this force makes the rotor start rotating.

Advantages

- Very simple and rugged construction
- Requires almost no maintenance
- Low cost and easily available
- High efficiency and reliable performance
- No brushes or slip rings

Disadvantages

- Low starting torque
- Speed control is difficult
- Not suitable for heavy starting load
- Cannot add external resistance to rotor
- Starting current is relatively high

Applications:

A squirrel cage motor is used in:

- **Pumps**—for water and fluid systems.
- **Fans and blowers**—in ventilation and air conditioning.
- **Compressors**—for air and refrigeration.
- **Industrial machines**—general manufacturing.

2. Wound Rotor or Slip Ring Induction Motor

Construction

The slip ring induction motor has a three-phase stator winding placed in slots to create the rotating magnetic field.



Its rotor is different from a squirrel cage motor because it has a three-phase winding connected to three slip rings on the shaft. Carbon brushes touch these slip rings so that external resistances can be added during starting.

The motor also includes a laminated core. Because of this wound-rotor construction, the slip ring induction motor can deliver high starting torque, better speed control, and smoother performance during heavy-duty operations.

Working

When a slip ring induction motor is supplied with three-phase AC, the stator creates a rotating magnetic field, just like in any other induction motor. This rotating field cuts the rotor windings and induces current in them. But unlike a squirrel cage motor, the rotor here has a three-phase winding connected to external resistances through slip rings and brushes.

During starting, these external resistances remain in the circuit. They increase the rotor resistance, which boosts starting torque and allows the motor to start smoothly even under heavy load. As the motor picks up speed, the external resistances are gradually reduced and finally shorted out. After that, the motor runs like a normal induction motor.

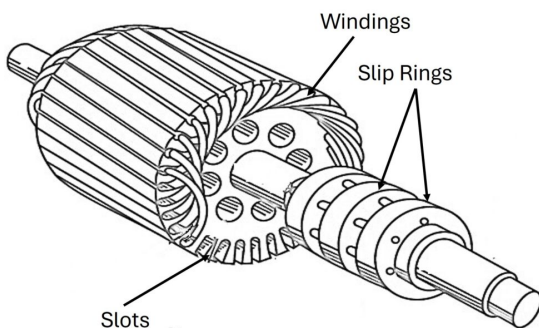



Advantages

- High starting torque due to external rotor resistance
- Smooth and wide speed control
- Lower starting current compared to squirrel cage motor
- Suitable for heavy-duty and loaded starting applications
- Better control during acceleration

Disadvantages

- More expensive than squirrel cage motors
- Requires regular maintenance due to brushes and slip rings
- Larger and heavier construction
- More complex design
- Higher chances of wear and tear

Applications

A slip ring induction motor is used in applications that require high starting torque and speed control. Common uses include:

- **Cranes and Hoists** - For lifting heavy loads.
- **Elevators** - To provide smooth starting and stopping.
- **Conveyors** - Where load variations are common.
- **Mining equipment** - For rugged operations.
- **Winders & milling machines** - In industrial settings for variable speed control.

Difference Between Squirrel Cage Induction Motor and Slip Ring Induction Motor

Point	Squirrel Cage Induction Motor	Slip Ring (Wound Rotor) Induction Motor
Rotor Type	Rotor has bars short-circuited by end rings, forming a cage	Rotor has a three-phase winding connected to slip rings



Point	Squirrel Cage Induction Motor	Slip Ring (Wound Rotor) Induction Motor
Construction	Very simple and rugged	More complex due to winding, slip rings, and brushes
Starting Torque	Low starting torque	High starting torque (using external resistance)
Starting Current	High starting current	Low starting current
Speed Control	Difficult and limited	Smooth and wide range of speed control
Maintenance	Very low; no brushes	Requires regular maintenance (brushes & slip rings)
Cost	Cheaper	Expensive
Applications	Fans, pumps, blowers, compressors, general industries	Cranes, hoists, elevators, heavy-duty conveyors, mills
Size & Weight	Smaller and lighter	Larger and heavier
Durability	Very durable and rugged	Less rugged compared to cage motors

FAQs

Why are the rotor bars of a squirrel cage motor skewed?

Rotor bars are skewed to reduce cogging, minimise noise, and ensure smooth starting.

Which motor is better for heavy-duty applications?

Slip ring induction motors are better for heavy-duty applications like cranes, hoists, and mills because they offer high starting torque and smooth speed control.

Why is it called a squirrel cage?

Because the rotor looks like a round cage made of bars connected by end rings — just like the wheel used for a squirrel in cartoons.



Which motor has higher starting torque?

The slip ring induction motor has higher starting torque because external resistances can be added to the rotor circuit during starting.